

Pump Coupling Guard Data Sheet

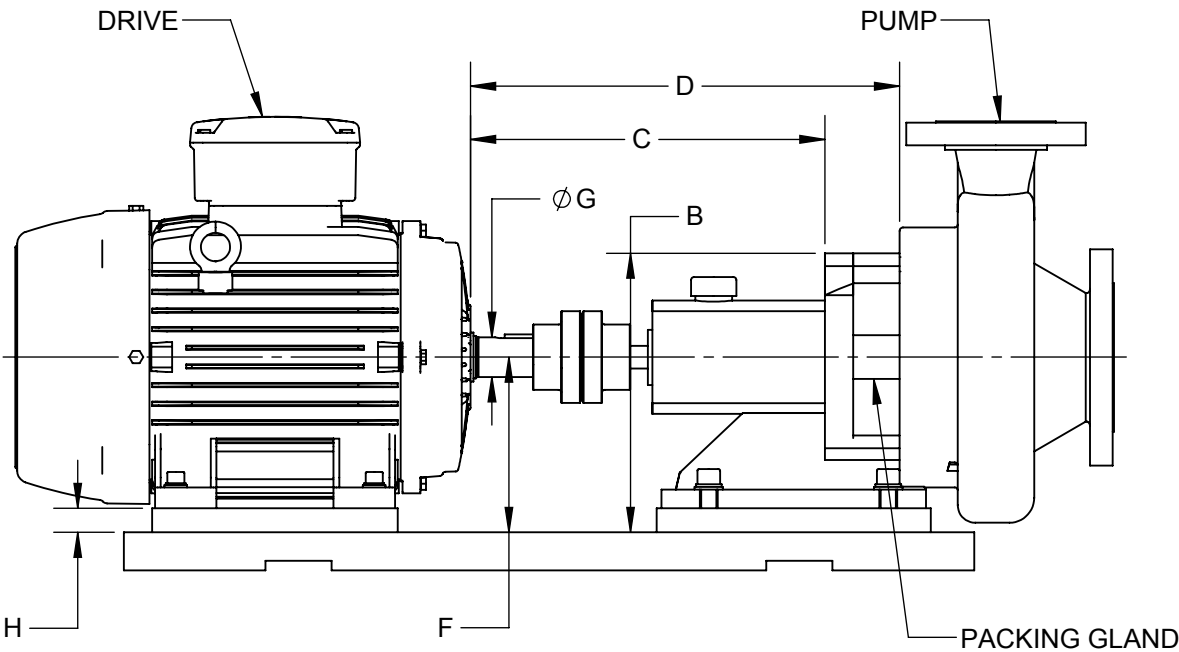

Required Dimensions		Value (in.)
A	Minimum Width of Guard	
B	Minimum Height of Guard	
C	Distance b/t Drive / Start of Packing Gland Opening	
D	Distance b/t Drive / End of Packing Gland Opening	
E	Support Frame Width	
F	Shaft Height	
G	Shaft Diameter	
H	Drive Base Plate Height	

Other Requirements	
Drive NEMA Frame/HP	
Support Frame Construction/Notes	
Other Notes:	
Any restrictions/interferences can be sketched on the views on the left marked up with corresponding dimensions.	

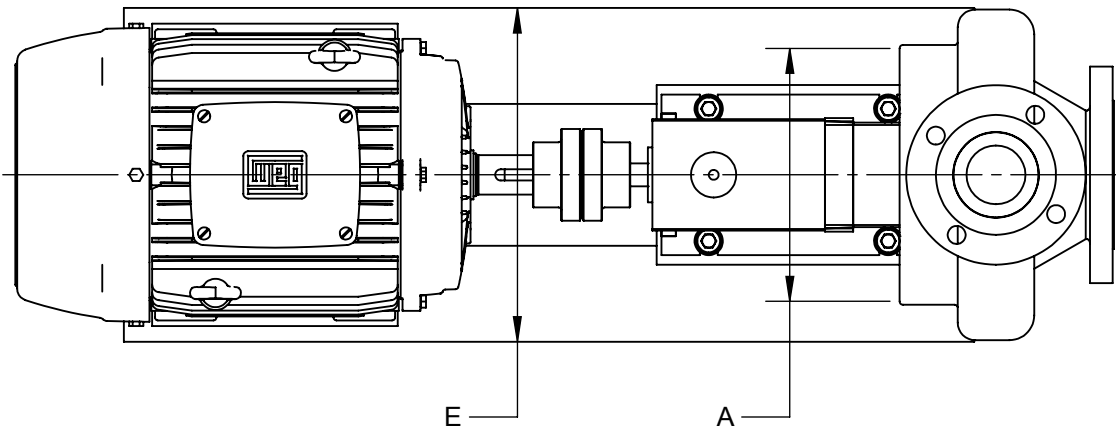

**Guard-Safe
Guarding**
Pearland, TX

Ph.: 281-485-2400
Fax: 281-485-2406
www.guardsafeguarding.com
sales@guardsafeguarding.com

Company:

Contact Name:

Phone No.:

Email:

Location/Equipment No.